



Tholu b.v.
industrial packaging services



FLUBOX FX SP





FLUBOX FX SP

INNER BOTTLE

Material	High density polyethylene with UV protection (neutral)
Production Method	Blow moulding
Maximum capacity	1.055 l.
Filling opening	150 mm (225 mm on request)
Emptying	Optimal

BUTTERFLY VALVE (DIN 50)

Material	High density polyethylene with UV protection (neutral)
Production Method	Injection moulding
Standard gaskets	ETFE / PE

CLOSURE LID

Material	High density polyethylene with UV protection (neutral)
Production Method	Injection moulding
Diameter	150 mm (225 mm on request)
Degasing (on request)	Hydrofobic membrane

STEELCAGE / PALLET

Cage material	Galvanised steel tubes (18x18 mm)
Production Method	Spotwelding
Pallet material	Plastic

FLUBOX

INNER-BOTTLE+VALVE+CLOSURE+CAGE+PALLET

Total weight	56 Kg. (+/- 3%)	
Stackability	1+1 (dynamic)	1+2 (static)
Transport in ISO container	18 pcs (ISO cont 20')	40 pcs (ISO cont 40')
Emptying	Optimal	

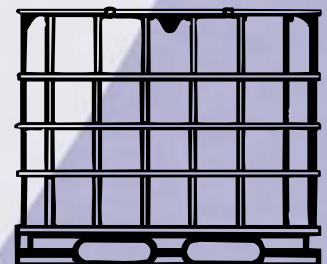
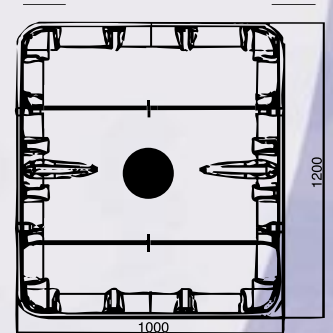
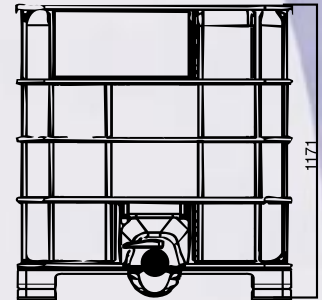

FUSTIPLAST S.p.A. is not liable for improper using of this products and is entitled to arrange technical specifications without prior advice.B59

PRECAUTIONS

- in case of reuse, the user has to check the IBC condition
- if necessary, change valve after each trip
- do not use filling goods exceeding 60° C
- protect from direct sunlight during storage